

PHD25

Performance data

- Operating temperatures -20°C bis 200°C
- Fastening via screws, piston automatically reverses and strikes the substrate or mounting surface
- Very high impact force - Especially for use in silos, hoppers and pipelines to prevent crust, bridge and vent formation.
- Maintenance-free, oil-free operation possible (lubrication increases service life)
- ATEX possible with special accessories
 - Zone 21 II 2D c T95°C/135°C/200°C/210°C
 - Zone 1 II 2G c T5/T4/T3/T2
- Noise level below 100 dB(A)



Typ	Vibration frequency [1/min]			Force [N]			Working torque [kg*cm]	Air consumption [l/min]		
	2 bar	4 bar	6 bar	2 bar	4 bar	6 bar		2 bar	4 bar	6 bar
PHD25	2500	3800	4500	294	680	954	0,43	55	80	200

Table 1: Performance data

Dimensions

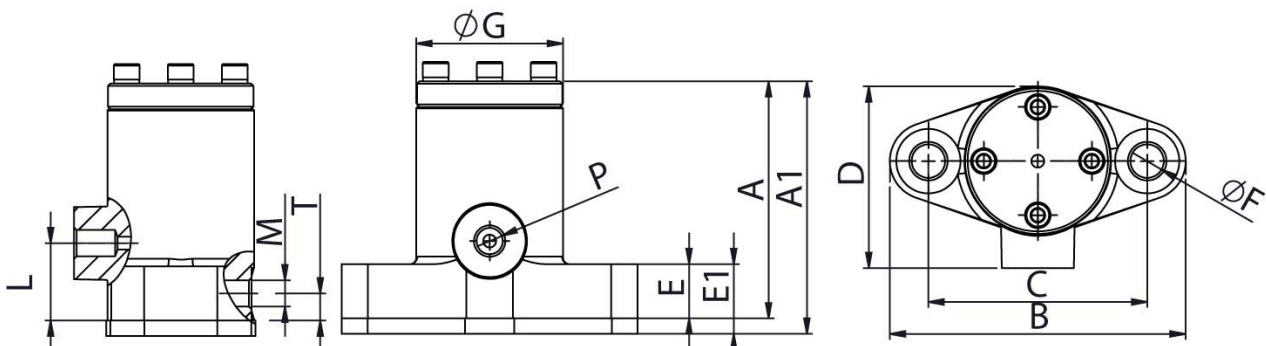

Typ	A	A1	B	C	D	E	E1	F	G	H	P	L	M	N	Weight
	mm	mm	mm	mm		mm		mm	mm			mm	mm	mm	[kg]
PHD25	92	98	115	85	70	21	27	13	58	30	1/4"	10,5	1/4"	25	2,2

Table 2: Dimensions